

mFix Recess for SOMFY Glydea with two motor ends

MOTOR BOX

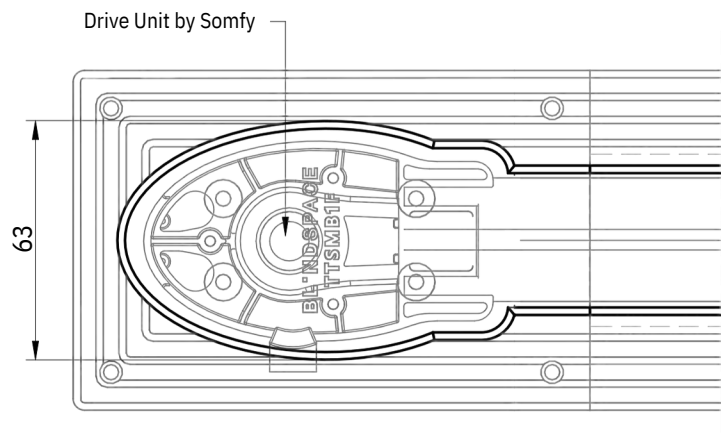

TRACK PROFILE

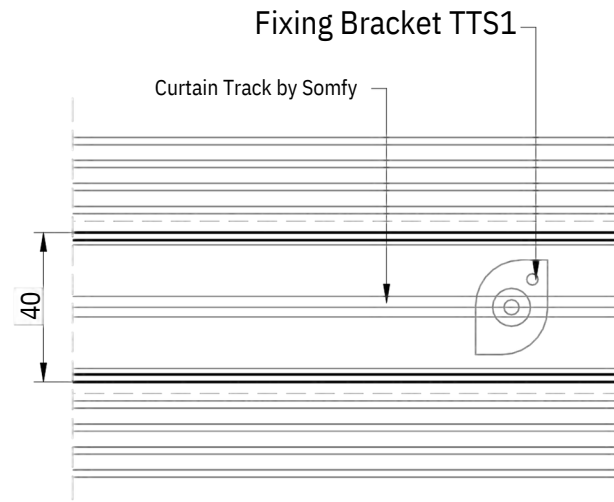

MOTOR BOX

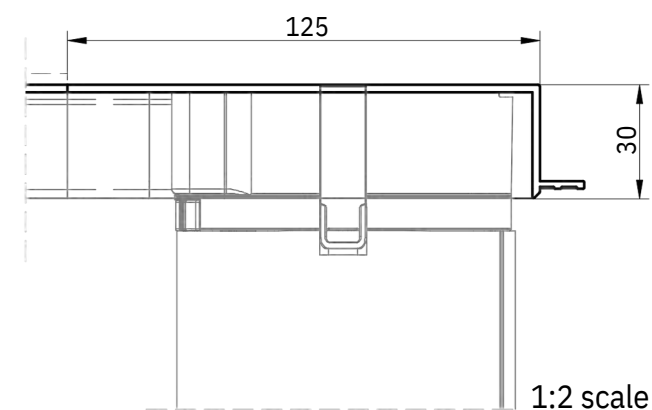
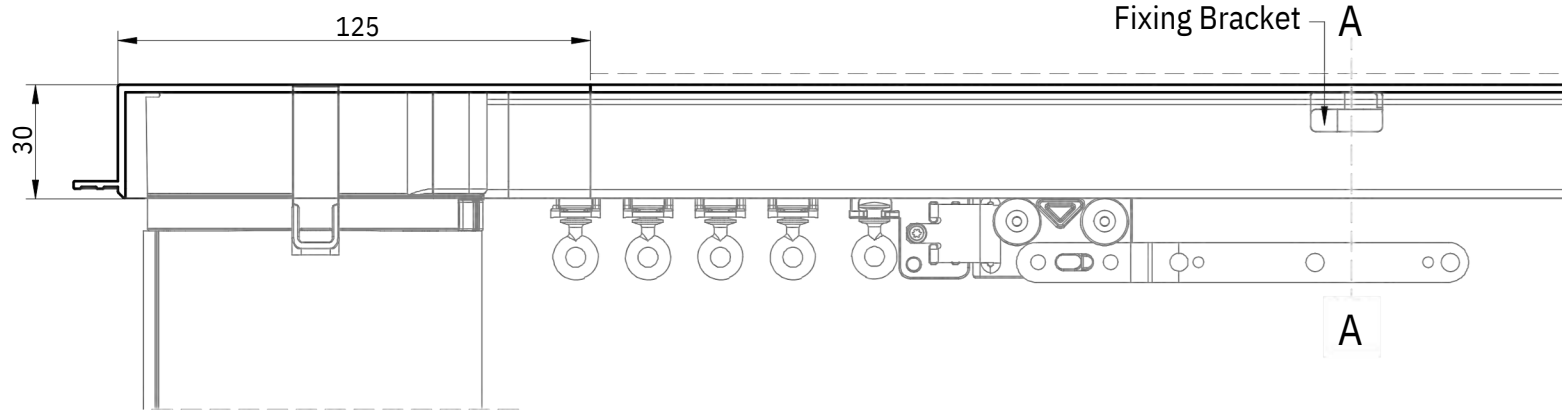
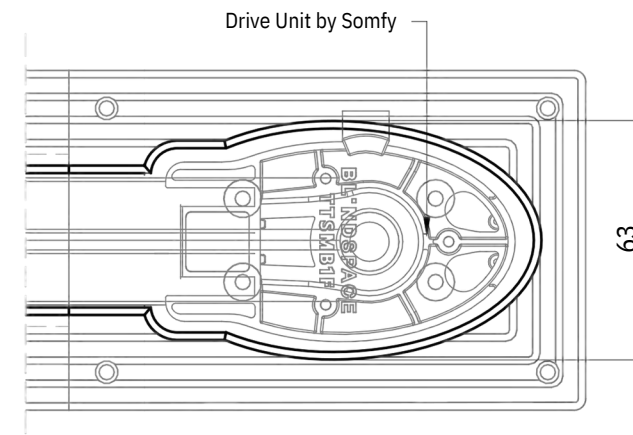

FIXING BRACKET

Fixing Bracket

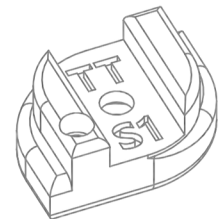

SECTION A-A TT1FPROFILE

Track with Screw Channel, possible Screw-Through Fixing

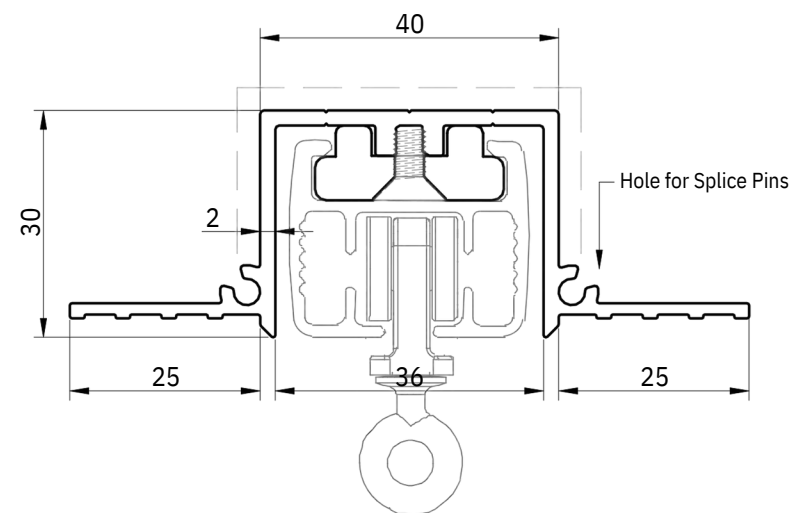

Product	mFix Recess
Description	Recessed profiles to house curtain tracks.
Curtain size	Please see size chart and supplier details for curtain such as max. length and weight.
Finishes	White to be plastered in and decorated at site to match ceiling.
Material	Track EN 6063 T6, End set PLA Thermoplastic Polyester
Optional accessories	Curve Sections for bent tracks Long Splice Pins for joining
Track length	2000mm Cut to size for shorter lengths. Spliced together for longer lengths.

mFix Recess
for SOMFY Glydea with motor end and return end

MOTOR BOX

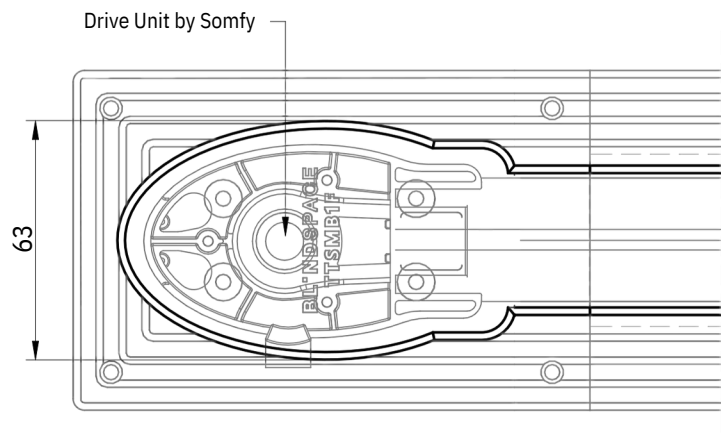

TRACK PROFILE

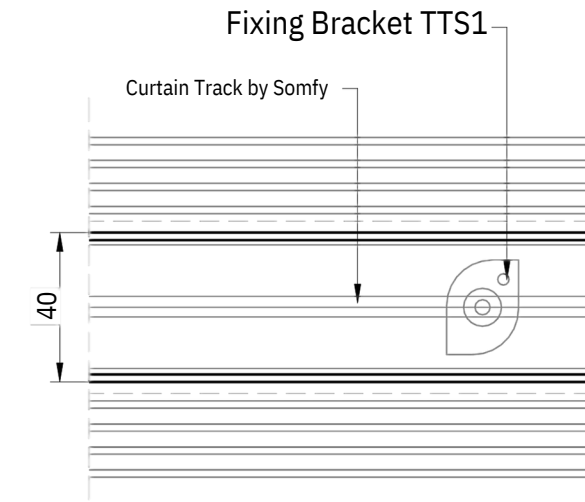

RETURN BOX

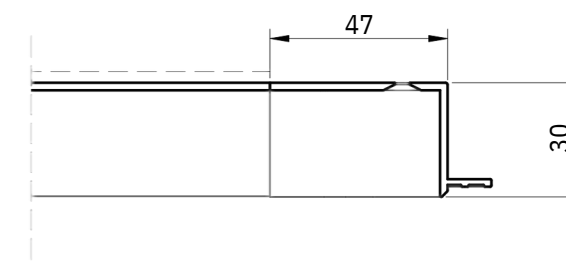
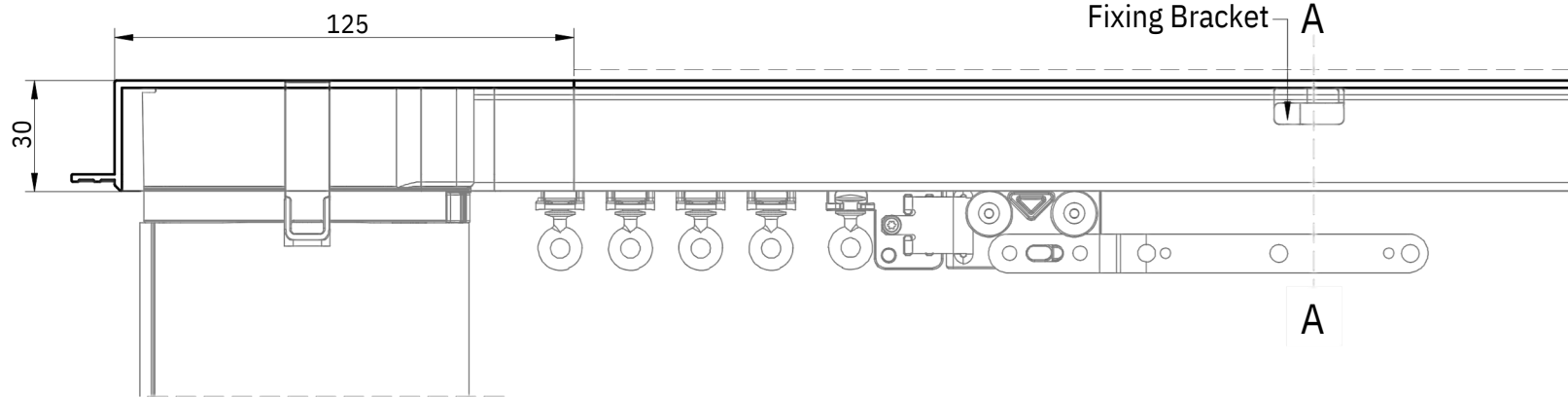
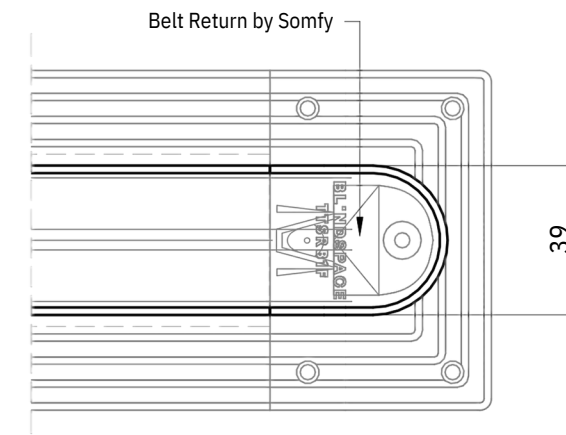

FIXING BRACKET

Fixing Bracket

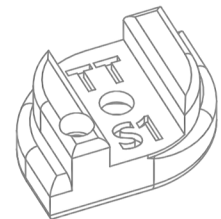

SECTION A-A TT1FPROFILE

Track with Screw Channel, possible Screw-Through Fixing

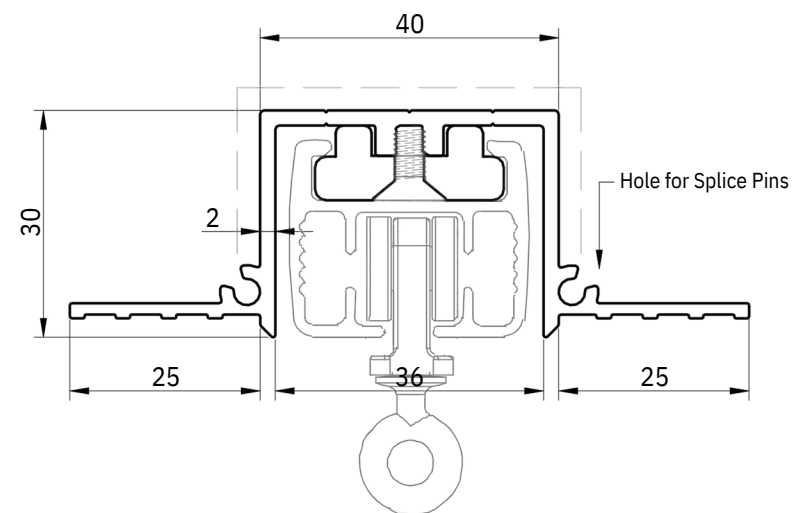

Product	mFix Recess
Description	Recessed profiles to house curtain tracks.
Curtain size	Please see size chart and supplier details for curtain such as max. length and weight.
Finishes	White to be plastered in and decorated at site to match ceiling.
Material	Track EN 6063 T6, End set PLA Thermoplastic Polyester
Optional accessories	Curve Sections for bent tracks Long Splice Pins for joining
Track length	2000mm Cut to size for shorter lengths. Spliced together for longer lengths.